

DO NOT SCALE - IF IN DOUBT ASK

ALL DIMENSIONS ARE METRIC UNLESS OTHERWISE STATED

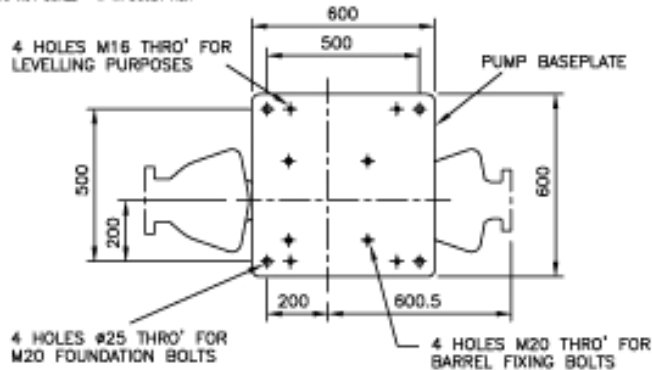

FOUNDATION DETAILS

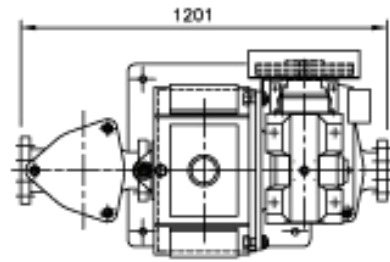

PLAN VIEW

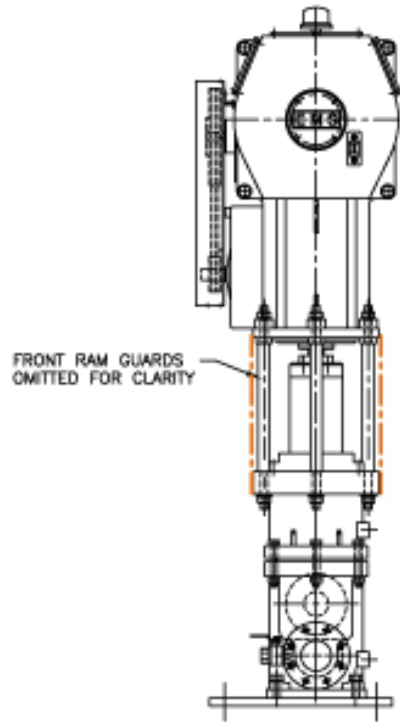

VIEW ON SUCTION SIDE

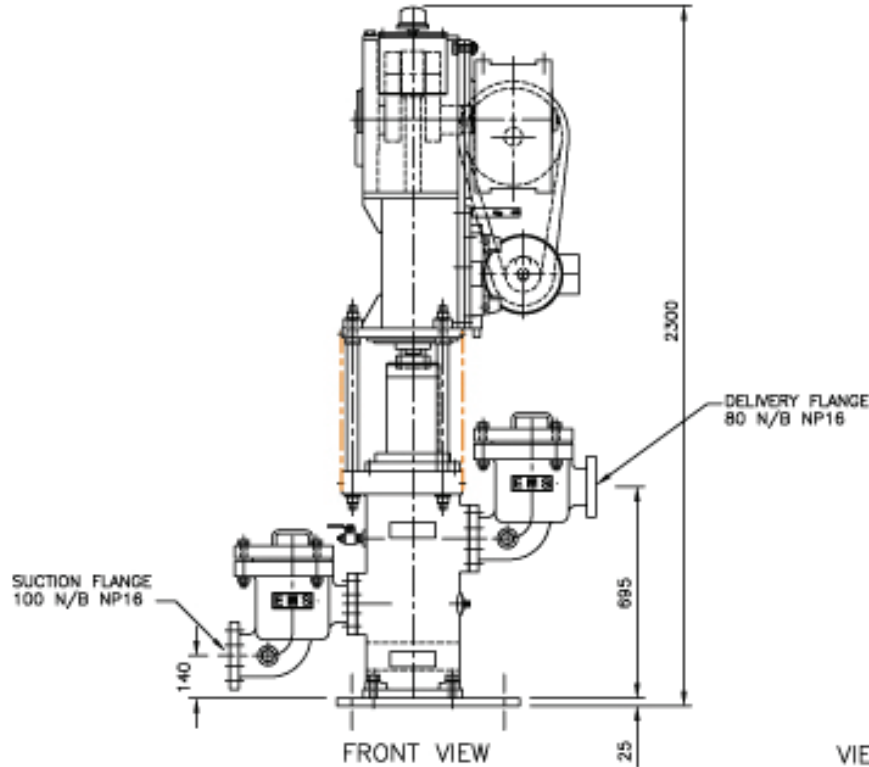

FRONT VIEW

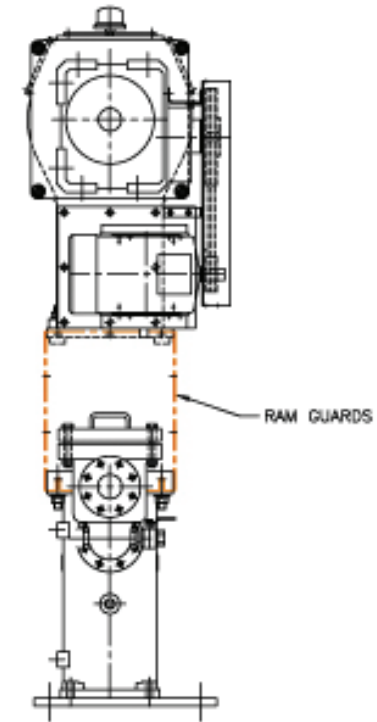

VIEW ON DELIVERY SIDE

CERTIFIED FOR			
<input type="checkbox"/> MANUFACTURE	<input type="checkbox"/> APPROVAL	<input type="checkbox"/> REFERENCE	<input type="checkbox"/> DECISION
CONTRACT No. _____		DATE _____	

ASSEMBLED WEIGHT = 1300 Kgs.

PART No. _____ A2

EMS EMS Industries Ltd
 7 Turaloo Road Industrial Estate, Kynessley, Stoke-on-Trent, ST8 7BD
 Telephone : (01782)510050 Fax : (01782)510052

REVISION
 'A' FIRST ISSUE

TOLERANCE UNLESS OTHERWISE STATED
 DIAIT ±1.5(0.067) FIN ±1.5(0.067) M/C ±0.25(0.01")
 MACHINE SURFACE UNLESS OTHERWISE STATED
 per No 1.8 to 3.2

ORDER No _____ QTY : _____
 MATERIAL _____
 FINISH _____
 THIS DRAWING IS CONFIDENTIAL AND IS THE PROPERTY OF
 EMS INDUSTRIES LTD IF MUST NOT BE DISCLOSED TO A THIRD
 PARTY COPIED OR LENT WITHOUT THE WRITTEN CONSENT OF
 EMS INDUSTRIES LTD.

DESCRIPTION
VRM175 GENERAL ARRANGEMENT

SCALE	DRAWN	HCP	17.10.03	DRAWING No.	REV
1:12	CHECKED			VRM175/ GA002	A